

Agri Star



PERFORMANCE

	37.7	37.8	35.10	38.10
Maximum capacity (kg)	3.700	3.700	3.500	3.800
Maximum lifting height (m)	7,35	7,93	9,75	9,75
Maximum horizontal outreach (m)	4,00	4,60	6,50	6,45
Outreach at maximum height (m)	0,20	0,35	0,84	0,84
Fork swivelling angle	130°	130°	130°	130°
Pull-out force (daN)	5.700	5.700	5.700	5.700
Towing force (daN)	7.300	7.300	7.300	7.300
Maximum climb angle	40%	40%	40%	40%
Total weight empty (kg)	7.100	7.400	7.700	7.900
Max speed (km/h)	30	30	30	30

(On request 40 Km/h)

BOOM**Times empty (in seconds)**

	37.7	37.8	35.10	38.10
Lifting	10,2	11,8	10,2	10,8
Descent	5,3	6,9	5,3	6,9
Extension	7,3	8,9	10,1	10,1
Retraction	4,1	5,4	7,0	7,0
Forward swivelling	3,7	3,9	3,9	3,9
Reverse swivelling	2,4	2,4	2,4	2,4

Patented compensation system

ENGINE

	Iveco NEF 74 Kw	Iveco NEF 93 Kw
Model:	Iveco NEF	Iveco NEF
Maximum power kW (hp):	74 (101)	93 (127)
Revolutions per minute (rpm):	2200	2200
Operation:	4 stroke diesel	
Injection:	Direct mechanical	
Number and arrangement of cylinders:	4, vertical in line	
Engine size (cm ³):	4485	4485
Specific consumption at 2200 rpm (g/kWh):	230	230
	Aftercooler Turbo compressor	
	Liquid cooling system	

OPTIONALS AND ACCESSORIES

A/C; Webasto Heater; Digital speedometer; Water Heater; Driver's seat with pneumatic suspension; Light on boom head; Quick coupling for accessories; Radio; Anti-theft system; Glass protection.

(For additional customizations, contact the area dealer)

TRANSMISSION

Hydrostatic transmission with variable displacement pump.

Hydrostatic engine with automatic variation.

Electrical - hydraulic inversion.

Inching pedal for controlled advancement.

Servocontrolled 2-speed gearbox.

HYDRAULIC PLANT

Gear pump with capacity at max. speed (lt/1'):	110
Max operational pressure (bar):	230
Distributor control with joystick:	3 in 1

DIFFERENTIAL AXLES

Steering axles: 2, with planetary reduction gears
Steering types: 4 wheels / transversal / 2 wheels
Front axle: rigid
Back axle: oscillating
Oil bath service braking on the front axle with servo brake
Negative action parking brake.

REFUELLING (Litres)

Hydraulic plant (total)	140
Fuel tank	95

DEVICES AS PER STANDARD

Anti-tipping device with pejorative movement block.

Hydraulic socket for any accessories on the boom head.

Soundproof closed cab, ROPS-FOPS approved, with heater.

Self-blocking front axle differential (limited slip 45%).

Electric window winder.

TOWING CAPACITY (upon request)

Trailer without brakes (ton):	3
Mechanical braking (ton):	5
Hydraulic/pneumatic braking (ton):	
74 kW engine	17.5
93 kW engine	20

Including 40 km/h speed

TYRES

Tyres	405/70x20"
Alternative	405/70x24"

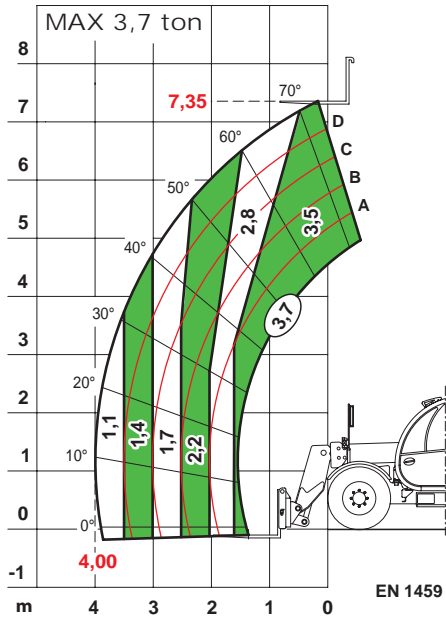

Agri Star 37.7

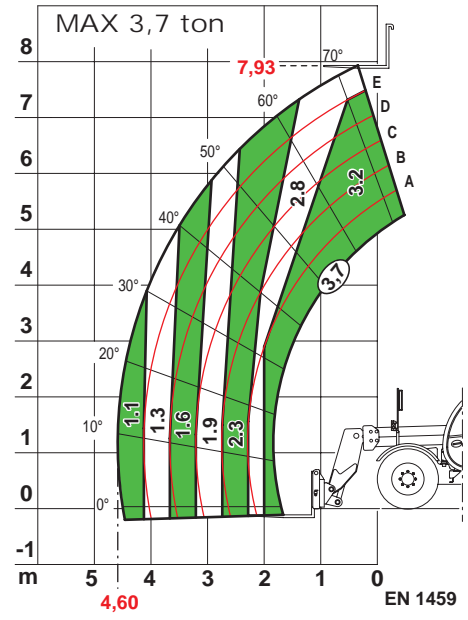

Agri Star 37.8

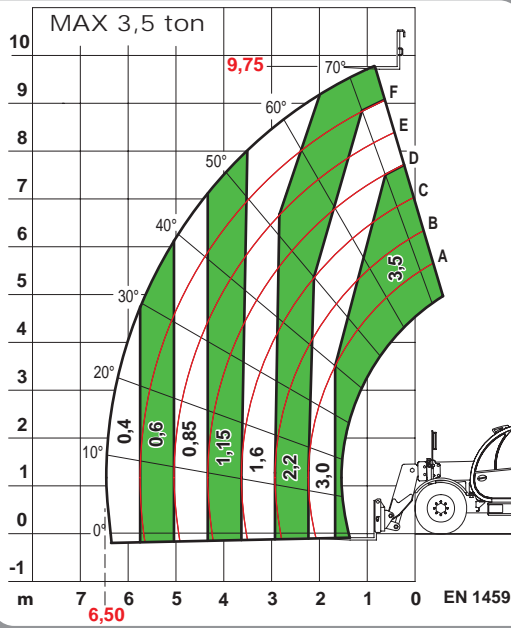

Agri Star 35.10

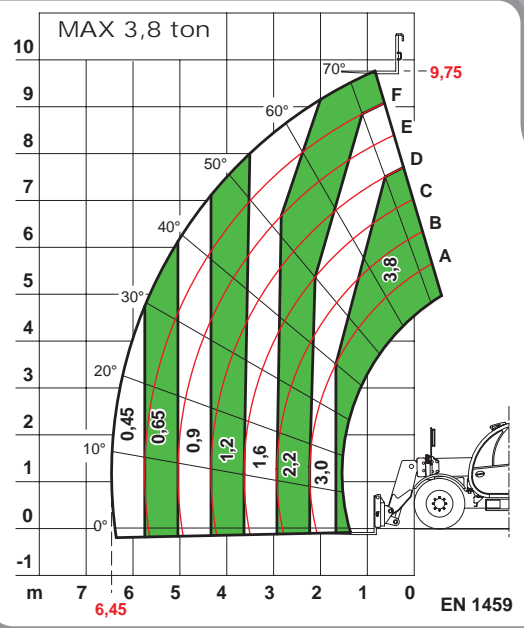

Agri Star 38.10

Accessories and Attachments specific for any need

Fork with three jointed prongs

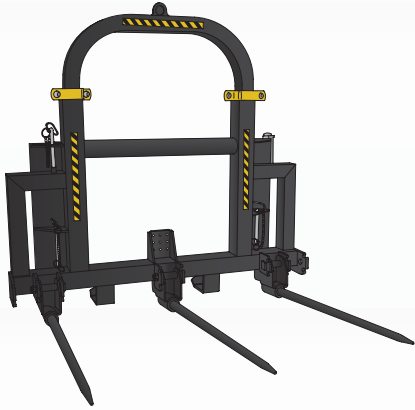

Bucket with teeth

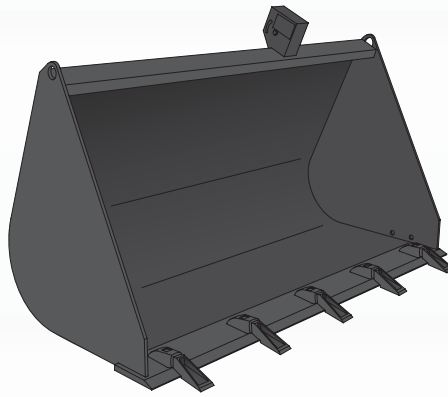

Clamp for logs

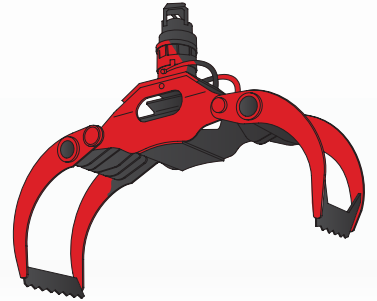

Bucket with holder

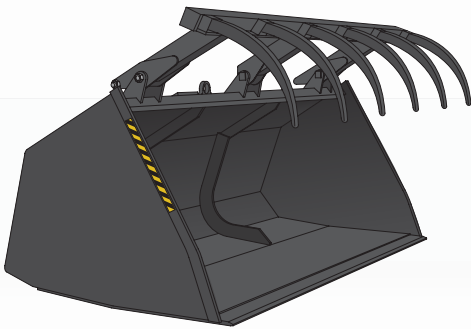

Bucket for silage

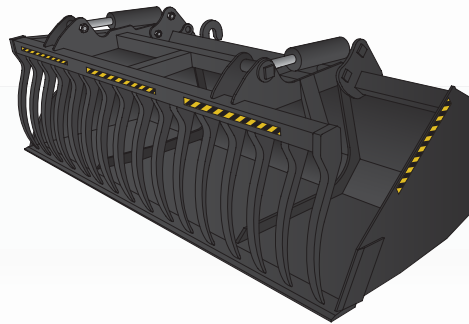

Boom suspension



Clamp for big wrapped bales

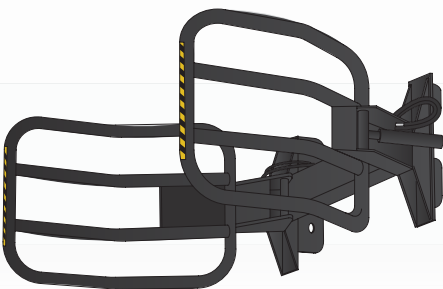

Multipurpose fork with holder

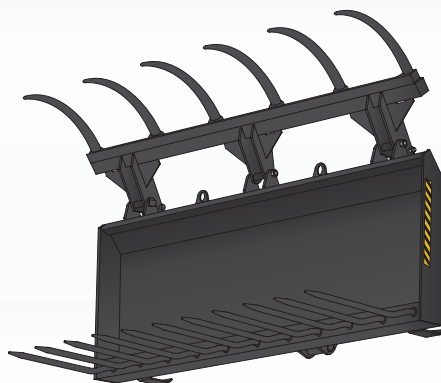

Clamp for two roll bales



This is only a part of the many accessories and various equipment available for Dieci machines.
For information about the entire range of accessories **CONTACT US** using contact information contained on the rear of the document



360° Visibility

From the significantly raised driver's seat, the innovative anti-fall protection system, located inside the cab, allows for a 360° view that is without comparison.

Two independent rear-view mirrors on both sides reduce blind spots to a minimum.



Comfort

A telescopic lift that takes care of everything... You will notice it immediately, equipped with the largest door on the market, accessing the driver's seat will no longer be a problem. The inside of the cab has been entirely designed in order to make work easier for the operator. Thanks to the integration of the armrest in the right instrument panel, it both reduces arm stress and provides greater accessibility to the joystick. The precise distribution of the ventilation grills optimises efficiency of the heating and air conditioning system, providing a perfect distribution of air inside of the cab.



Engine: low consumption, high yield

Designed for intense use, they guarantee a high level of reliability over time. The new TIER III engines guarantee remarkable elasticity providing maximum power, even at low engine speed and an unparalleled low operational noise level.

This, along with the possibility of equipping the machine with a particle filter, provides for drastic reduction of consumption.



Safety

For us, safety is an absolute priority, it is guaranteed by an electronic system, standard on all models, which makes it possible to always keep the weight on the forks or on equipment under control during work manoeuvres.

The load limiter flexibly and accurately manages both standard equipment and that used for specific applications.



Design

Dieci has always considered design a significant aspect when engineering their own products.

This philosophy is evident when considering the newly designed cab and chassis restyling.

Paying particular attention, Dieci engineers have been able to interpret the request of a comfortable and functional compartment, creating a spacious and ergonomic cab with snappy styling.



Great agility and reduced steering radius

One of the characteristics that distinguish Dieci telescopic devices the most is workability. The extremely reduced steering radius combined with high capacity axles make the machine both agile and powerful. The four drive wheels and the possibility of steering the wheels in three different modes, make it possible to operate on any type of land. Muddy ground, mountain areas, tight spaces and many other extreme conditions will no longer be an obstacle.

DIMENSIONS

	37.7	37.8	35.10	38.10
A/A*	440/480*	440/480*	440/480*	440/480*
B	1380	1680	1380	1380
C	2600	2600	2600	2600
D	970	970	970	970
E/E*	4110/4160*	4110/4160*	4110/4160*	4110/4160*
F	4950	5250	4950	4950
G	940	940	940	940
H/H*	2310/2360*	2310/2360*	2310/2360*	2310/2360*
I	1780	1780	1780	1780
L	2220	2220	2220	2220
M	4810	5060	4810	4810
N	1240	1240	1240	1240
O	3840	3840	3840	3840

Measurements expressed in millimetres

A* - E* - H* = Measurements referring to optional wheels

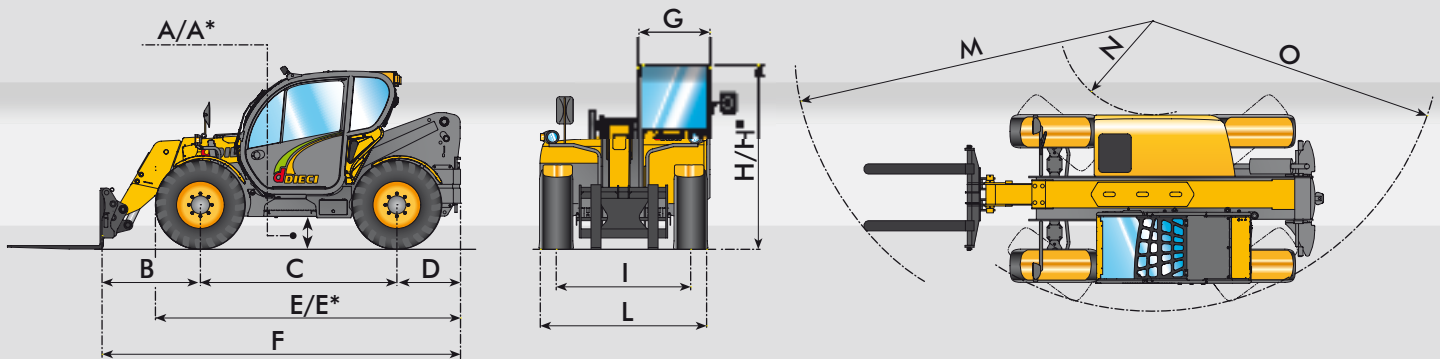

A* - E* - H* = Measurements referring to optional wheels



dDIECI
macchine edili ed agricole

Via E. Majorana, 2-4 42027 Montecchio Emilia (RE) ITALY

Tel. +39 0522 869611 Fax +39 0522 869791 (comm. le Estero) Fax +39 0522 869604 (comm.le Italia)

www.dieci.com - E-mail: info@dieci.com